

TENDER SPECIFICATION

BHEL: PSSR: SCT: 1448

FOR

Handling at Site Stores / Storage yard, Transportation to Site of Work, Erection, Testing and Commissioning of Electrical works including illumination

at

**PHASE-III, MRPL 122MW CO-GEN CPP,
MANGALORE, KARNATAKA**

VOLUME – I BOOK - I

CORRIGENDUM DATED: 24/01/2011



BHARAT HEAVY ELECTRICALS LIMITED

(A Government of India Undertaking)

Power Sector – Southern Region

690, Anna Salai, Nandanam, Chennai – 600 035

CORRIGENDUM TO TENDER NOTICE SCT 1448

TENDER SPECIFICATION NO BHEL: PSSR: SCT: 1448

1. The job description in the Cover page & Annexure –1 in the NIT in Volume 1A Book- 1 may be read as follows:-

ANNEXURE - 1**PRE QUALIFYING CRITERIA**

JOB DESCRIPTION	Handling at Site Stores / Storage yard, Transportation to Site of Work, Erection, Testing and Commissioning of Electrical and Controls & Instrumentation works for the MRPL Phase-III 122MW Co-Generation CPP at Mangalore, Karnataka
-----------------	----------------------------------------------------------------------------------------------------------------------------------------------------------------------------------------------------------------------------------------------

2. 'Total' at the end of the Volume- 2 Rate schedule is added after the item no 228. Hence the sum of the amount as "total" may be furnished at the end by the bidders.

Total-----

[§] Rate to be quoted only for commissioning

* Lump sum rate to be quoted per set

3. The T&Ps in contractors scope in PART – I CHAPTER – IV is modified as follows

T&PS and MMEs TO BE DEPLOYED BY CONTRACTOR

The following minimum Tools & Plants shall be deployed by the contractor:

All T & Ps **other than the cranes specified in BHEL scope**, Consumables such as Electrodes, Gases, Ferrules, lugs (for sizes upto 2.5 sq mm) etc., and testing instruments and tools are to be arranged by the contractor at his cost.

4. **Clarifications sought by the bidder on 21/01/2011 at BHEL PSSR in the Pre Bid Meeting of MRPL Electrical tender SCT 1448 is furnished below for your information.**

Tender Ref Clause	Bidder's query	BHEL Clarification
Rate Schedule item 215 Supply scope of Fire proof sealing of cables	Kindly clarify the Scope supply of Fire proof sealing of cables by BHEL or by bidder	BHEL will supply
Rate Schedule item 196 Lighting pole/lighting mast	Please clarify the scope of painting and provide the drawings for the Light poles/Masts	Typical drawings for high mast light and light poles are attached for information only. Only touch up painting, if required, has to be carried out by the contractor as per scope of painting.
Vol 1A Part I, Chapter III 1.3.4 electricity	Please clarify the provision of energy meter	Will be provided by BHEL free of hire charges and to be installed by the bidder
Vol 1A Part I, Chapter V T&P by BHEL	Please provide suitable capacity crane minimum 75T on sharable basis free of hire charges for Bus ducts/GTs/STs/UATs erection	Bidder to arrange the required crane within the quoted rates.
Vol 1A Part I, Chapter II 1.2.2.1 Inter connecting the new plant with existing plant by cabling	Please clarify the supply scope of tarfelt (Bituminus) during the closing of the trench after laying the cables	Bidder 's scope

Please visit www.bhel.com to view corrigendum

ALL OTHER CONDITIONS AND DUE DATE OF TENDER SUBMISSION REMAIN UNCHANGED.

**AGM / CONTRACTS
BHEL/PSSR/CHENNAI**

FIRST ANGLE PROJECTION

(ALL DIMENSIONS ARE IN mm)

THE INFORMATION ON THIS DOCUMENT IS THE PROPERTY OF BHARAT HEAVY ELECTRICALS LIMITED. IT MUST NOT BE USED DIRECTLY OR INDIRECTLY IN ANY WAY DETRIMENTAL TO THE INTEREST OF THE COMPANY

COMPUTER FILE NAME
PEEC03592R00-SHEET.17.DWG

REF. DRG. NO.

SIGN. AND DATE

INVENTORY NO

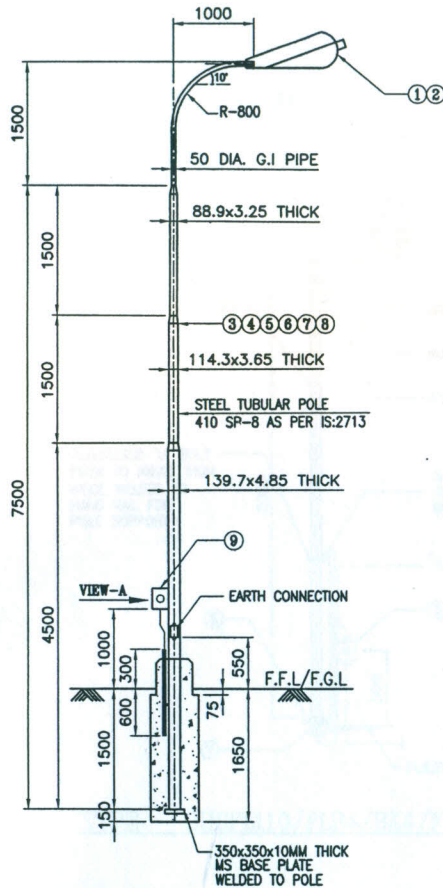

(7.5M HIGH ABOVE ROAD LEVEL)
(TYPE - ST9-PM)

NOTES:-
1. ALL G.I PIPE SHALL BE MEDIUM GRADE.

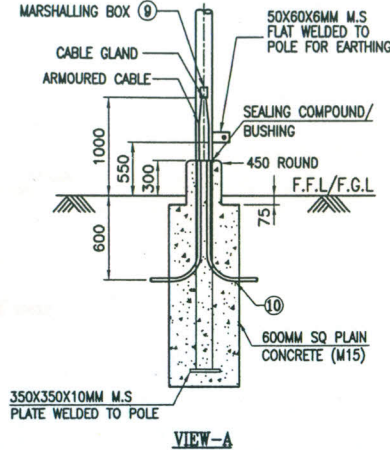

ITEMS. NO.	LIGHT FITTING TYPE	POLE DESCRIPTION	POLE HEIGHT (MTRS) (H)	PLANTING DEPTH (MTRS) (H4)	HEIGHT ABOVE GROUND (MTRS) (H5)	LENGTH OF SECTION (MTRS)			O.D & THK (MILLIMETERS)		
						(H1)	(H2)	(H3)	(H1)	(H2)	(H3)
03	70W HPSV	410 SP-8	7.5	1.50	6.00	4.50	1.50	1.50	139.7x4.85	114.3x3.65	88.9x3.25
04	70W HPSV	410 SP-15	8.0	1.50	6.50	4.50	1.75	1.75	139.7x5.40	114.3x4.50	88.9x3.25
05	150W HPSV	410 SP-38	9.5	1.80	7.70	5.00	2.25	2.25	165.1x4.85	139.7x4.50	114.3x3.65
06	150W HPSV	410 SP-42	10.0	1.80	8.20	5.20	2.40	2.40	139.7x5.40	114.3x4.50	88.9x3.25
07	150W HPSV	410 SP-54	11.0	1.80	9.20	5.60	2.70	2.70	165.1x5.40	139.7x4.50	114.3x3.65
08	250W HPSV	410 SP-58	12.0	2.00	10.00	5.80	3.10	3.10	165.1x4.50	139.7x4.50	114.3x3.65

REMARKS	NO. ITEMS.	DESCRIPTION	MATERIAL SPECIFICATION	UNIT
			MATERIAL CODE	QTY
	1	(INDUSTRIAL TYPE) LIGHTING FIXTURE	----	NO 01
	2	HPSV/HPMV LAMP	GT9757137049	NO 01
	3	LIGHTING POLE	----	NO 01
	4	LIGHTING POLE	----	NO 01
	5	LIGHTING POLE	----	NO 01
	6	LIGHTING POLE	----	NO 01
	7	LENGTH AS REQD	----	NO 01
	8	LIGHTING POLE	----	NO 01
	9	MARSHALLING BOX	----	NO 01
	10	40MM GI PIPE	----	NO 02



BHARAT HEAVY ELECTRICALS LTD.
HYDERABAD

CAPTIVE POWER PLANT,
MANGALORE REFINERY & PETROCHEMICALS LTD.,
PHASE-III REFINERY PROJECT,
MANGALORE

TITLE

TYPICAL INSTALLATION OF
STREET LIGHTING FIXTURE
(TYPE - ST9-PM)

DRG. NO.

PEEC-03592

REV.

00

SHT. No. 17

No. OF SHT. 21

FIRST ANGLE PROJECTION

(ALL DIMENSIONS ARE IN mm)

THE INFORMATION ON THIS DOCUMENT IS THE PROPERTY OF BHARAT HEAVY ELECTRICALS LIMITED. IT MUST NOT BE USED DIRECTLY OR INDIRECTLY IN ANY WAY DETRIMENTAL TO THE INTEREST OF THE COMPANY

COMPUTER FILE NAME
PEEC03592R00-SHEET.18.DWG

REF. DRG. NO.
SIGN. AND DATE

INVENTORY NO

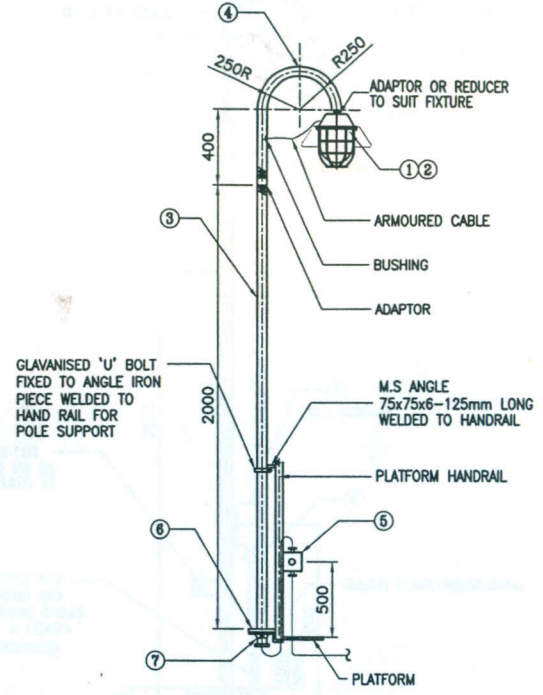

TYPE - BHCFL110/FLP4/BK4/FWCFL29-HR

- NOTES:-
1. ALL DIMENSIONS ARE IN MM.
 2. TYPE OF FIXTURE USED SHALL BE INDICATED ON THE LAYOUT DRAWING BY DESIGNATION AND IDENTIFIED FROM DATA SHEET FOR LIGHTING FIXTURE SCHEDULE.
 3. ALL G.I. PIPES SHALL BE MEDIUM GRADE.

REMARKS	NO. ITEMS.	DESCRIPTION	MATERIAL SPECIFICATION	
			MATERIAL CODE	UNIT
	1	LIGHTING FIXTURE (INDUSTRIAL TYPE)	----	NO 01
	2	FLUROSCENT LAMP/HPMV (125W) LAMP	----	NO 01
	3	50 DIA. G.I PIPE	----	NO 01
	4	50 DIA. G.I PIPE	----	NO 01
	5	JUNCTION BOX	----	NO 01
	6	M.S ANGLE 100x75x6-100mm LONG	----	NO 01
	7	REDUCER 50/25	----	NO 01



BHARAT HEAVY ELECTRICALS LTD.
HYDERABAD

CAPTIVE POWER PLANT,
MANGALORE REFINERY & PETROCHEMICALS LTD.,
PHASE-III REFINERY PROJECT,
MANGALORE

TITLE
TYPICAL INSTALLATION OF
LIGHTING FIXTURE ON PLATFORM
TYPE - BHCFL110/FLP4/BK4/FWCFL29-HR

DRG. NO. PEEC-03592	REV. 00
SHT. No. 18	No. OF SHT. 21

FIRST ANGLE PROJECTION

(ALL DIMENSIONS ARE IN mm)

THE INFORMATION ON THIS DOCUMENT IS THE PROPERTY OF BHARAT HEAVY ELECTRICALS LIMITED. IT MUST NOT BE USED DIRECTLY OR INDIRECTLY IN ANY WAY DETRIMENTAL TO THE INTEREST OF THE COMPANY

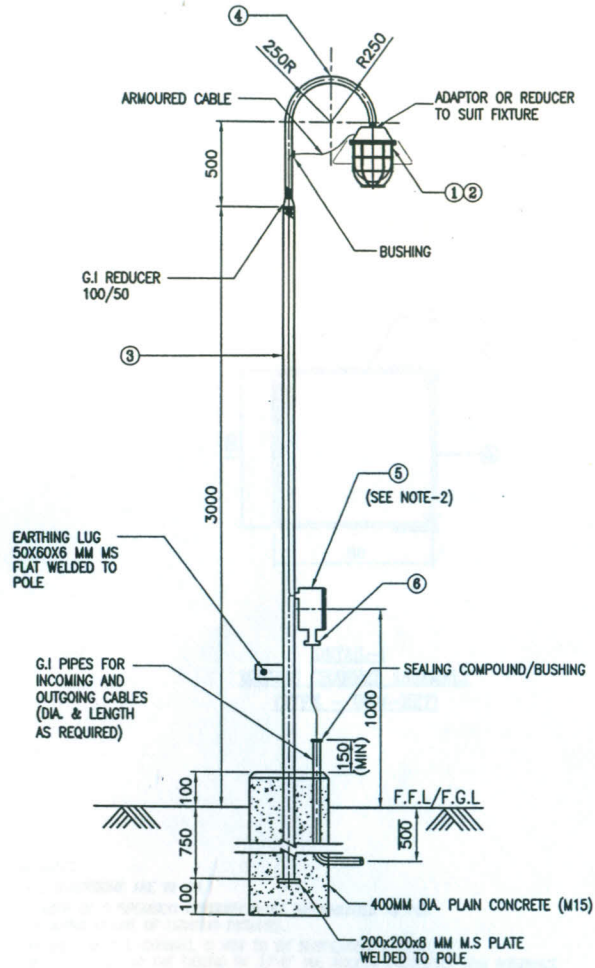

TYPE - BK4/FLP4-PM3

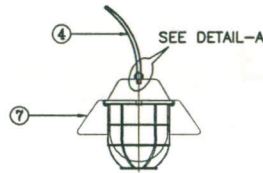

**DETAIL-1
POLE MOUNTED**

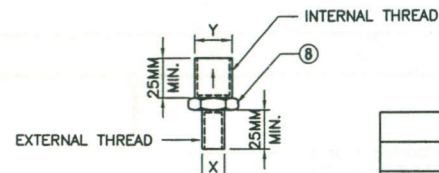

**DETAIL-A
(ADAPTOR)**

DIMENSIONS	
X	Y
* TO SUIT 19 DIA.	TO SUIT 50 DIA.

* ALTERNATIVELY SIZE TO SUIT FIXTURE

NOTES:-

1. ALL DIMENSIONS ARE IN MM.
2. MARSHALLING BOX, JUNCTION BOX AND G.I PIPES FOR CABLES SHALL BE LOCATED FACING CABLE TRENCH SIDE.
3. ALL G.I PIPES SHALL BE MEDIUM GRADE.

COMPUTER FILE NAME
PEEC03592R00-SHEET.19.DWG

REF. DRG. NO.

SIGN. AND DATE

INVENTORY NO



BHARAT HEAVY ELECTRICALS LTD.
HYDERABAD

**CAPTIVE POWER PLANT,
MANGALORE REFINERY & PETROCHEMICALS LTD.,
PHASE-III REFINERY PROJECT,
MANGALORE**

TITLE
TYPICAL INSTALLATION OF
LIGHTING FIXTURE AT GROUND LEVEL
TYPE - BK4/FLP4-PM3

DRG. NO.	REV.
PEEC-03592	00
SHT. No. 19	No. OF SHT. 21

REMARKS	NO. ITEMS.	DESCRIPTION	UNIT
			QTY
	1	LIGHTING FIXTURE (INDUSTRIAL TYPE)	NO 01
	2	FLUORESCENT LAMP/HPMV/HPSV	NO 01
LENGTH AS REQD	3	100 DIA. G.I PIPE	NO 01
	4	50 DIA. G.I PIPE	NO 01
	5	MARSHALLING BOX	NO 01
	6	CABLE GLAND	NO 04
	7	EXTERNAL REFLECTOR	NO 02
	8	HEXAGONAL HEAD	NO 01